



Including the Lesa Dominator Joint System



ENGINEERED CONCRETE FLOOR SYSTEMS

ARMOUR JOINT TYPE A1, A2 & A3™

Slab joint armouring that is installed in conjunction with timber formwork.

Dominator ARMOUR JOINT™

Fully assembled joint armouring system with formwork & Lesa® dowels.

ARMOUR JOINT TYPE C™

Slab joint armouring for existing to new slabs.

ARMOUR JOINT TYPE E™

Fully assembled joint armouring system with built in allowance for expansion.

ARMOUR JOINT TYPE F™

Pre-assembled joint armouring for use in Hollow-Core or Double T topping slabs.

ARMOUR JOINT TYPE G™

Three versions (Types G45, G65, and G85) utilising a sliding cover plate.

ARMOUR JOINT TYPE G-C™ & REMOVABLE COVER PLATE™

Use Type G-C for existing to new slabs that require a sliding cover plate. Also available with removable cover plate.

ARMOUR JOINT TYPE H™

Fully assembled joint armouring system c/w formwork & dowels for wider joint openings.

ARMOUR JOINT TYPE K™

Lesas budget version of Type B, pre-assembled c/w formwork & dowels.

ARMOUR JOINT TYPE L™

A comprehensive fully assembled joint armouring system c/w formwork, dowels and Type G top section.

ARMOUR JOINT TYPE M™

A pre-assembled version using steel angles for medium trafficked slabs.

ARMOUR JOINT TYPE P™

Fully assembled joint armouring system using steel angles, c/w formwork & dowels.

SPEED-FORM™

A fully assembled formwork & dowel system for light to medium traffic situations.

T-FORM™

A pre-assembled sacrificial formwork system c/w dowels, used to create a movement joint in monolith pours.

SPEEDSCREED™

A leave-in-place, pre-assembled heavy duty screed rail to enable Super Flat or VNA slab construction.



► LESA® SYSTEMS ARMOUR JOINT RANGE

p. 1

Introduction

p. 3

Armour Joint Type A1, A2, A3

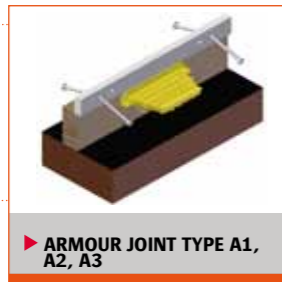

p. 4

Dominator Armour Joint

p. 5

Armour Joint Type C

p. 6

Armour Joint Type E



p. 7

Armour Joint Type F

p. 8

Armour Joint Type G

p. 9

Armour Joint Type G-C



p. 10

Armour Joint Type H

p. 11

Armour Joint Type K

p. 12

Armour Joint Type L



p. 13

Armour Joint Type M

p. 14

Armour Joint Type P

p. 15

T-Form

p. 16

Speed-Form

p. 16

Speedscreed

p. 17

FAQ



▶ **What is Lesa® Armour Joint™?**

Lesla® Armour Joint™ is a complex permanent formwork system for creating and protecting movement joints in concrete slabs on ground. It incorporates anchored steel armouring at the concrete edges, and includes dowels for load transfer across the joint.

▶ **Where is Lesa® Armour Joint™ Used?**

Lesla® Armour Joint™ is used in concrete slabs on ground.

▶ **Three Primary Functions**

There are three primary functions in most versions of Armour Joint.

1. The full depth sheet steel creates the joint, and defines where movement will appear
2. Steel armouring protects the concrete edges from spalling damage.
3. Dowels transfer live loads across the joint.

▶ **A Little History**

The first product in the Lesla® Armour Joint™ range was designed in 1999 to solve problems associated with previous concrete slab design methods.

Earlier design systems for conventional slab construction resulted in floors with many joints, with a mix of construction joints and sawcut joints, which gave little control over which joints shrinkage movement appeared in, or the width of joints. The construction of joints which were damage resistant was then expensive, and rarely achieved.

Lesla® Systems' Armour Joint, which was the first product of its type in the world, enabled the introduction of improved design and detailing methods which control widths of floor joints in conventionally constructed floors.

The shrinkage movement of the concrete is focused into fewer joints, at wider joint spacing. These joints can be protected against damage, and dowels are incorporated to suit the joint width and loading.

▶ **Floor Design Systems**

There are three primary design approaches for concrete slabs on ground:

1. Conventional construction, both reinforced and un-reinforced.
2. Steel fibre Reinforced, both low dosage and high dosage (also known as joint free).
3. Prestressed.

Each of these approaches has advantages and disadvantages, and Lesla® Armour Joint™ is suitable for and is widely used in all three. A summary is as follows:

Concrete slabs on ground differ from most other structural concrete components, as the concrete is used in tension. Concrete tensile stresses must be kept low enough to avoid cracking. Cracking in floor slabs (except under sawcuts) is undesirable, and unnecessary with proper design and detailing..

One of the major functions of joints in floor slabs is to limit the level of concrete tensile stress which occurs.



INTRODUCTION
TYPE A1, A2 & A3

► **Conventionally Constructed Floors**

These floors are the most common, being the traditional method of construction. The slabs usually include either bar or mesh reinforcing, though it can be argued that the reinforcing is usually unnecessary. Joints are created in both directions at quite close centres, typically at about 6 metres. At this spacing, cracks are unlikely to occur between the joints. Both construction joints and sawcut joints are used, to suit pour layouts.

Joint widths and shrinkage movement can be controlled with proper detailing of the slabs and the use of defined movement joints. Traditionally this was not the case. The use of Lesa® Armour Joint™, typically at about 25 metre centres in each direction, focuses all the shrinkage movement into the relatively small number of joints which are armoured to prevent spalling damage.

Joint widths usually do not exceed about 15mm, and Lesa® Armour Joint™ Types A, B and K are suitable for the movement joints. Dowels are often eliminated in sawcut joints, by using full reinforcing to hold these joints closed. This reduces cost. High quality and economical floors can be constructed with this simple formula.

► **Steel Fibre Reinforced Floors**

Steel fibre reinforced slabs fall into two distinct categories:

- a) Low dosage slabs;
- b) High dosage (jointless or joint free) slabs.

In low dosage steel fibre slabs, a low level of steel fibre reinforcing is substituted for conventional reinforcing. The joint types and spacings are similar to conventional slabs. Lesa® Armour Joint™ Types A, B and K are suitable for the movement joints. Dowels are advisable in sawcut joints.

High dosage steel fibre slabs have different performance characteristics, and the reinforcing is used to increase the structural strength. Movement joints are often located at 35 - 40 metre centres or greater, without sawcuts between the movement joints. This results in a very high quality slab.

Joint widths are typically no more than 20mm, and rarely exceed 25mm. At these joint widths, an armour joint which includes a cover plate is advisable. Lesa® Armour Joint™ Type L40 is the most commonly used product for high dosage steel fibre reinforced floors.

► **Pre-stressed Floors.**

Prestressed floors use stressing cables to place the concrete under pre-compression, prior to live loads being applied. This increases the "available" tension in the concrete, allowing thinner slabs and wider joint spacing. Construction joints, which also become movement joints, are frequently spaced 40 metres or more apart, but there are no sawcuts between these joints.

Total contraction movement in prestressed floors can be significant. In addition to full concrete shrinkage, strain shortening will occur over time. Joint widths of 30mm are common, and in extreme cases can reach about 70mm. Lesa® Armour Joint™ Types G45, G65, G85, L45 and L65 are commonly used in prestressed concrete floors.

► **The Product Range.**

The Lesa® Armour Joint™ range has been extended significantly since the original design, to allow for the many types of floor slab construction, including wide and very wide joints, as occurs in jointless steel fibre reinforced slabs, and prestressed slabs.

The following Lesa® Armour Joint™ Types are available:

► **Lesas® Armour Joint Types A1™, A2™ & A3™ ©1999**

Types A1, A2 and A3 provide floor joint edge protection using square edged steel flat bars positioned vertically. All Type A versions are used with timber formwork and do not include dowels. Type A1 is pre-assembled for mounting on top of a timber form. Type A2 has one pre-drilled side for nailing to formwork. The second side is tack-welded to side one. Welds are cut following the concrete pour to allow concrete shrinkage to take place. Type A3 is pre-drilled to allow side one to be nailed to formwork for the first concrete pour. The second side is pinned to the first side after formwork is stripped from the first pour. Type D is a version of Type A1, which is used for doorways, sometimes with a 10mm step across it.

► **TYPE A1**

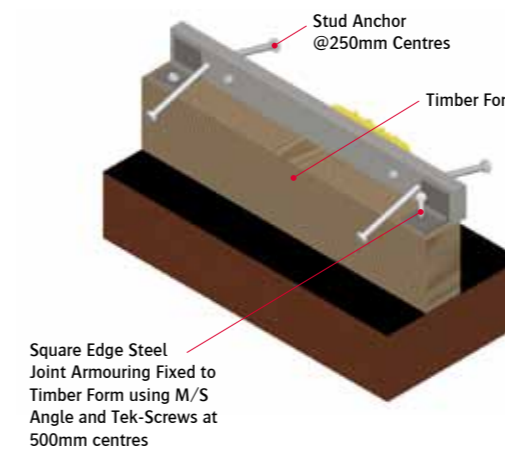

► **TYPE A2**

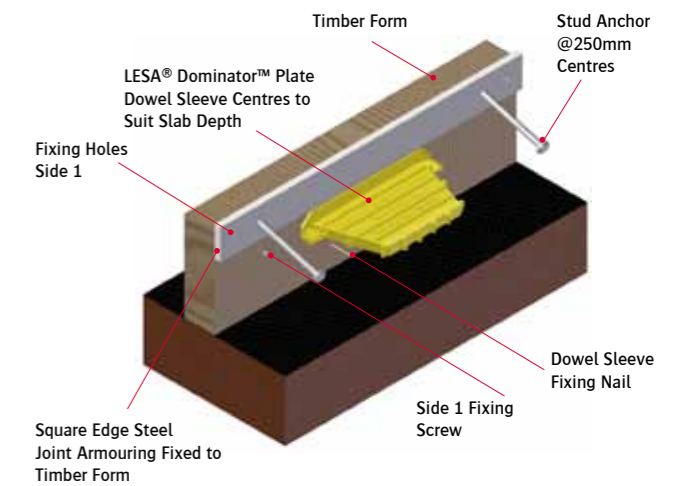

► **TYPE A3**

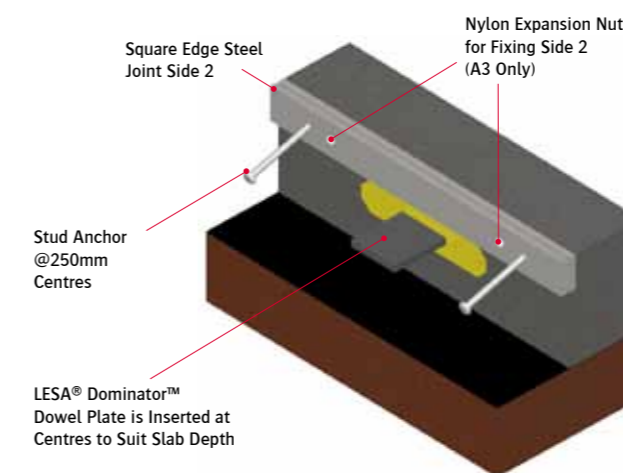

► **NOTE: OPTIONAL STEP AVAILABLE**

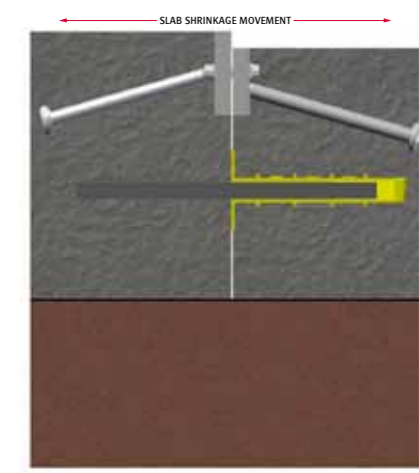

SECOND POUR

► Lesa® Dominator Armour Joint™ ©1999

Dominator Joint provides proven flat bar steel edge protection, incorporated into a full, comprehensive pre-assembled formwork system which includes a sheet metal steel form and Dominator Dowels at spacings to suit the slab thickness. A range of sizes is fabricated to suit the slab thickness. The use of Dominator Dowels caters for joint widths up to 25mm in most floors.

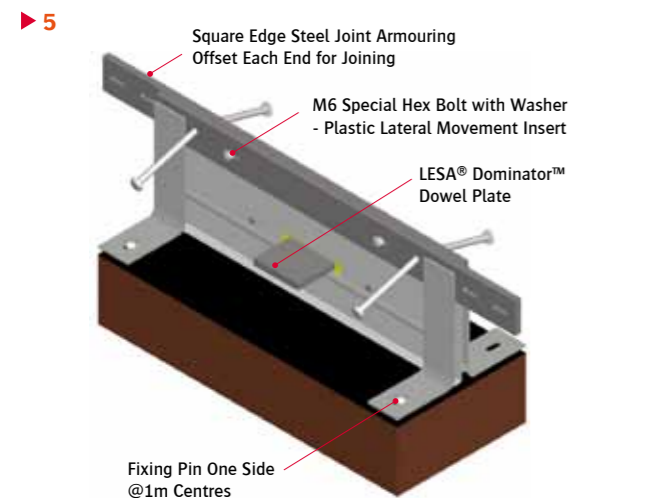
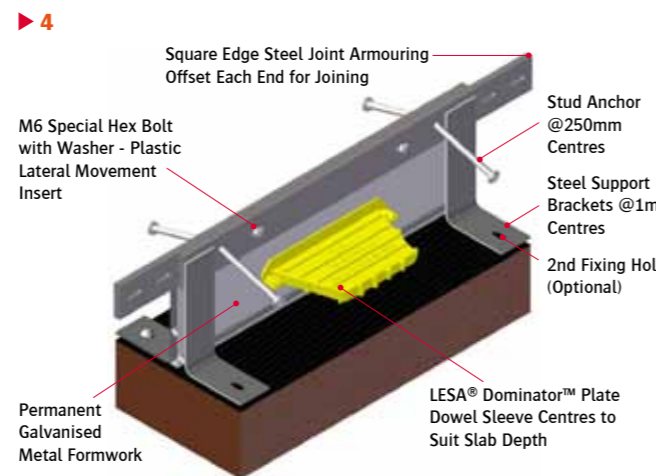
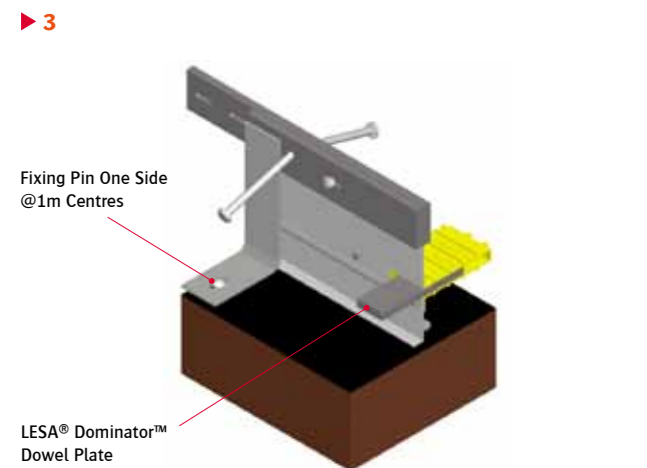
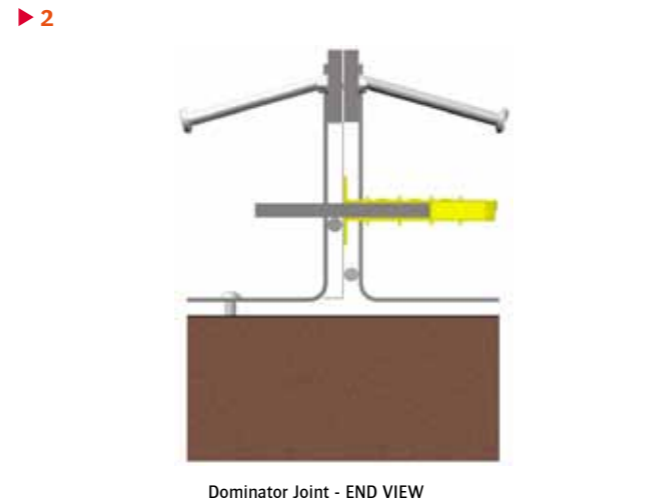
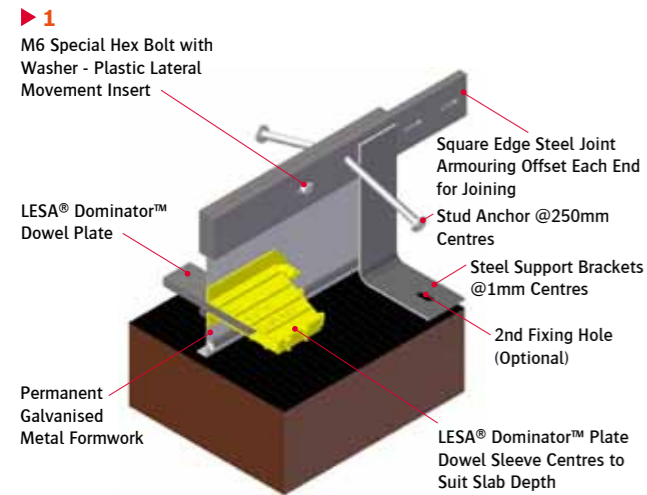

Lesa Dominator Joint is the mainstream version for general use and has been in production since 1998.

Contractor experience indicates that it is cheaper to use pre-assembled Dominator including dowels, than to use Type A plus timber formwork and separated dowels. It allows for continuous pour over the joint, but can also be used as an edge form.

► Lesa® Armour Joint Type C™ ©2000

Type C provides flat bar steel edge protection, for use when casting a new slab against an existing slab. Side one is bolted to anchors drilled into the existing concrete. Side two is pinned to side one and cast into the new concrete.

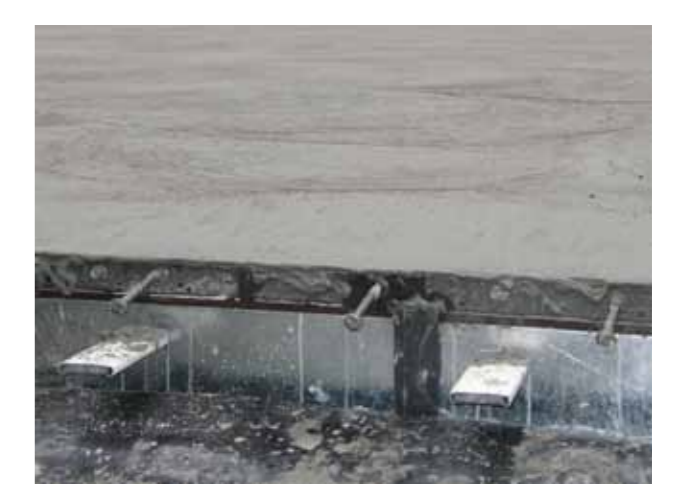
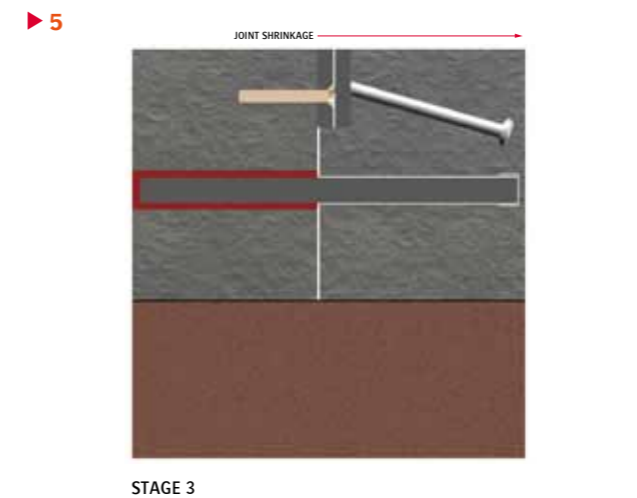
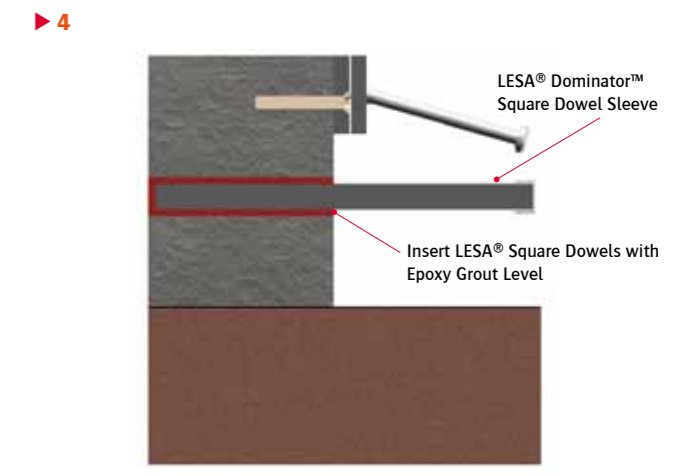
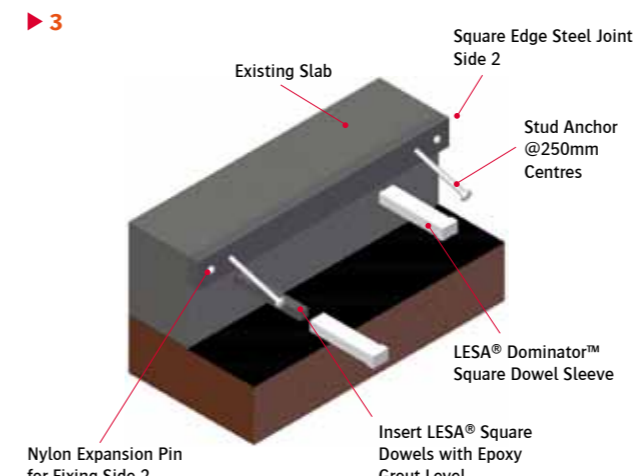
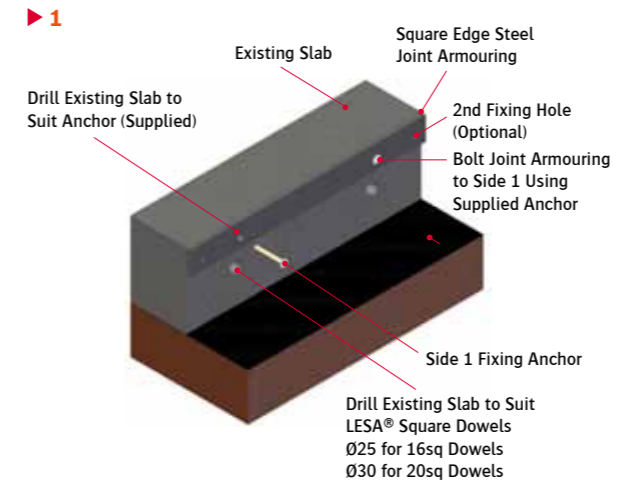

TYPE B

TYPE C

LESA® ARMOUR JOINT TYPE E™

LESA® ARMOUR JOINT TYPE F™

► Lesa® Armour Joint Type E™ ©2004

Type E is a fully pre-assembled flat bar steel edge protection system similar to Type B, modified to create an expansion joint. It incorporates a central compressible material, to meet the requirements of hot climate markets and shrinkage compensating concrete slabs.

► 1

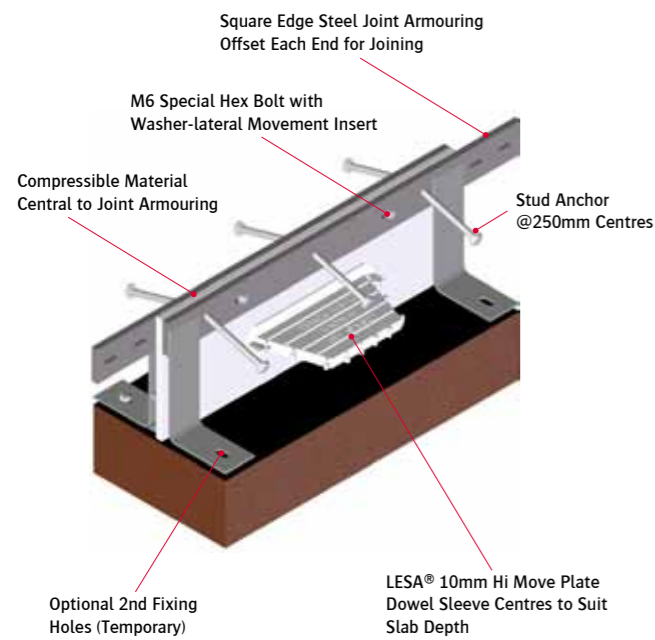

► 2

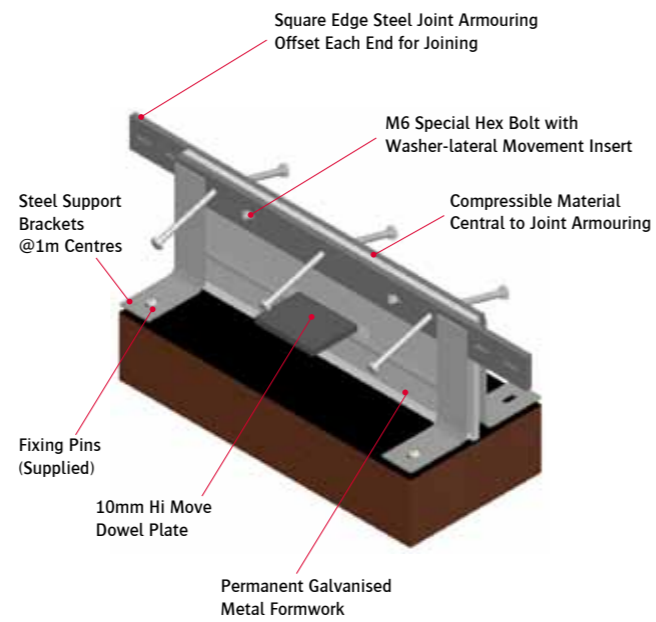

► 3

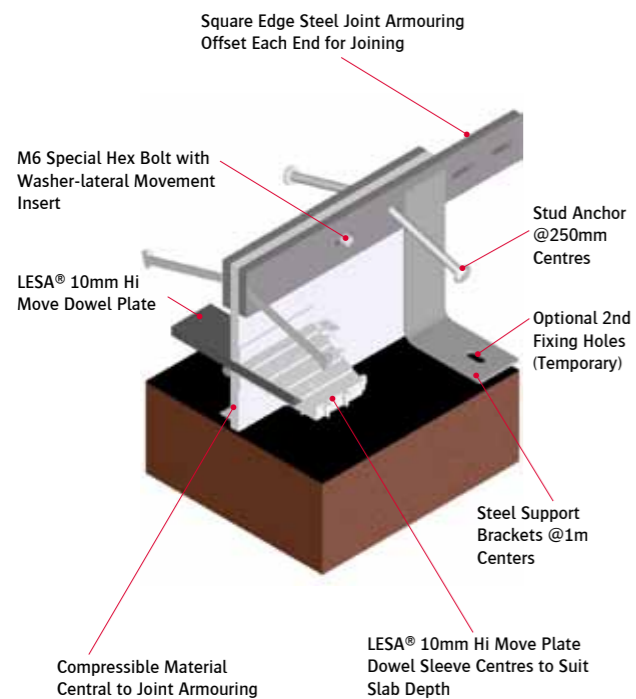

► 4

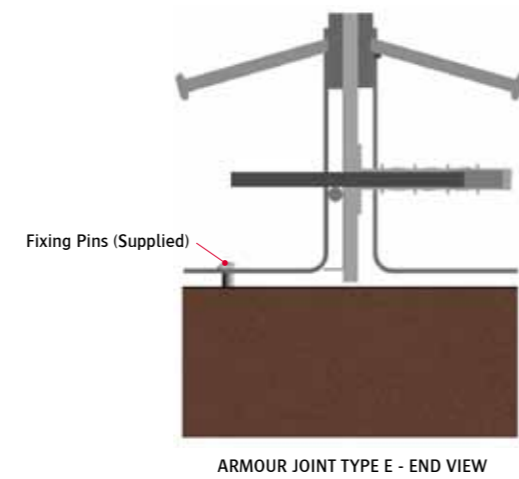

TYPE E
TYPE F

► Lesa® Armour Joint Type F™ ©2004

Steel angle edge protection for use in suspended precast floors, such as hollow-core etc. This ensures a straight and spall proof crack line where reflective cracking regularly occurs, over panel joints, in the topping slabs.

► 1

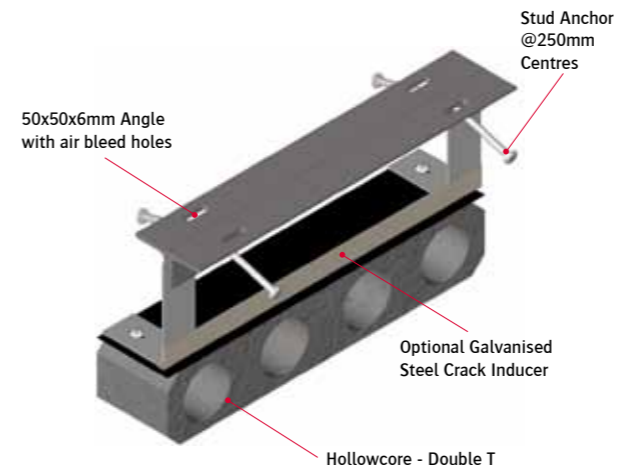

► 2

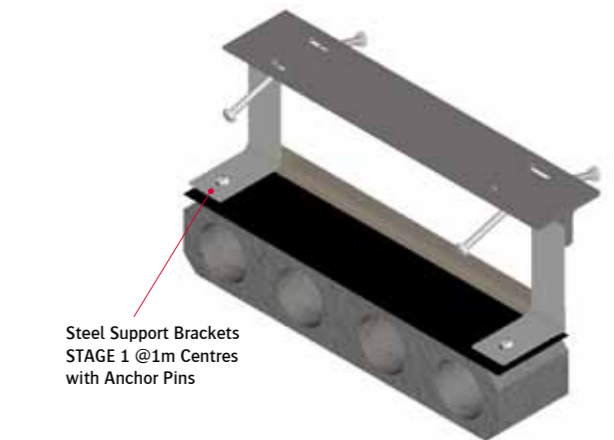

► 3

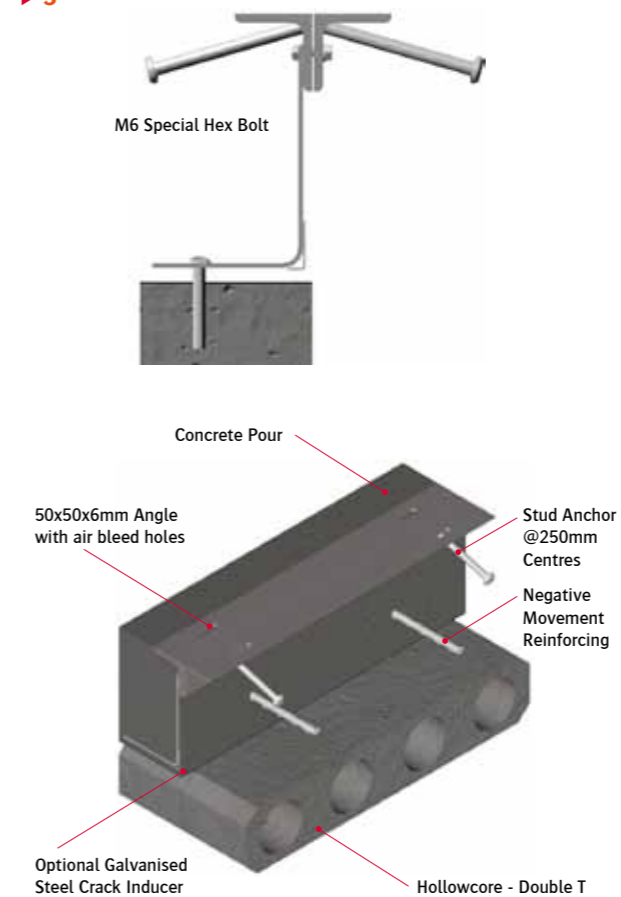

► 4

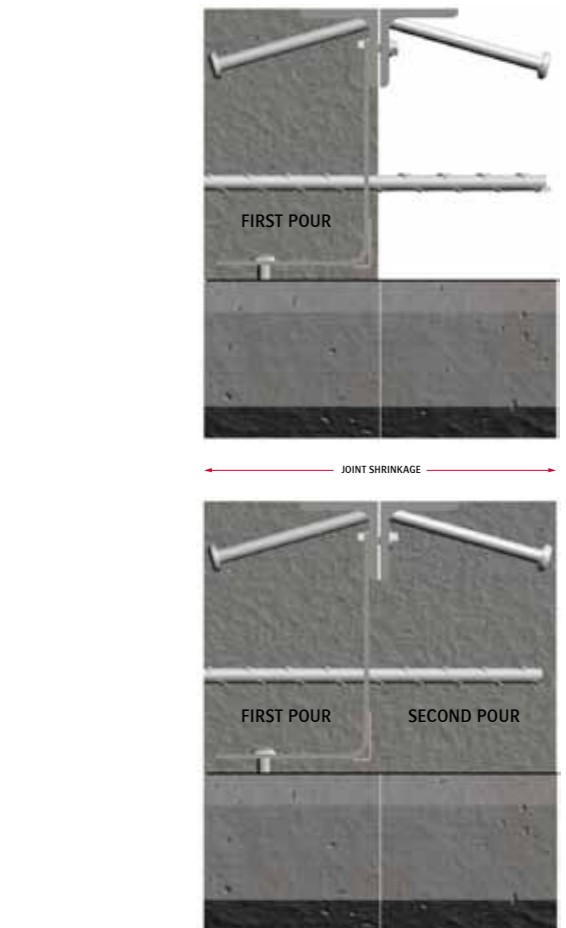

LESA® ARMOUR JOINT TYPE G™ - FOR JOINT OPENINGS 45MM, 65MM & 85MM

▶ Lesa® Armour Joint Type G™ ©2003 / Type G-Removable™ ©2008 (With Removable Cover Plate)

Type G provides a sliding cover plate joint system for a range of floors where high joint movement occurs due to the wide joint spacing. Type G is used in stressed slabs, jointless (high dosage) steel fibre slabs and shrinkage compensating concrete slabs. It has been in use since 2003. A robust cover plate slides over the joint as floor shrinkage occurs. Three versions (Types G45, G65, and G85) provide for joint widths up to 85mm.

▶ 1

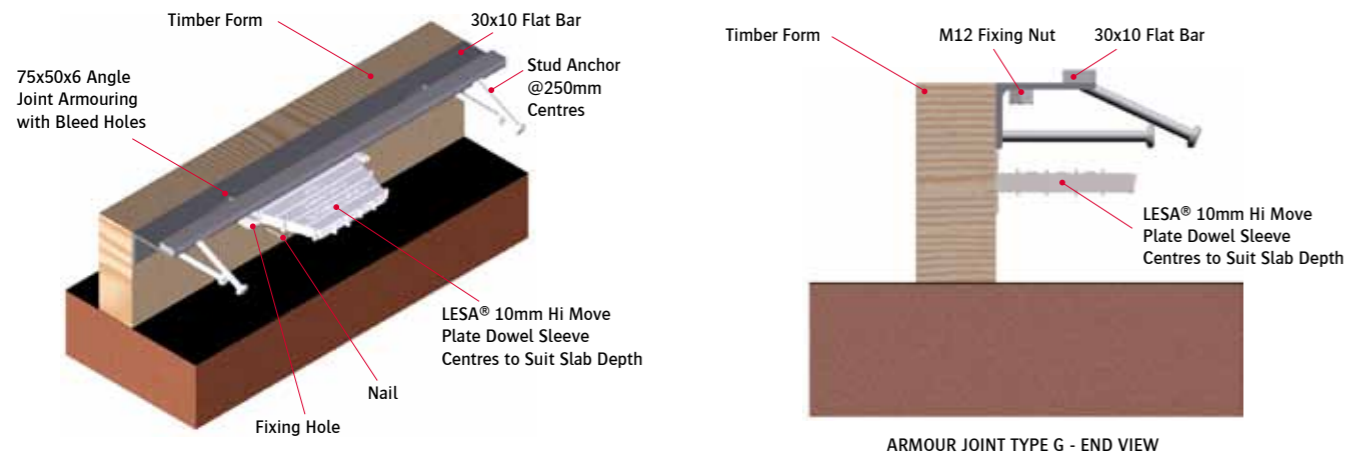

▶ 2

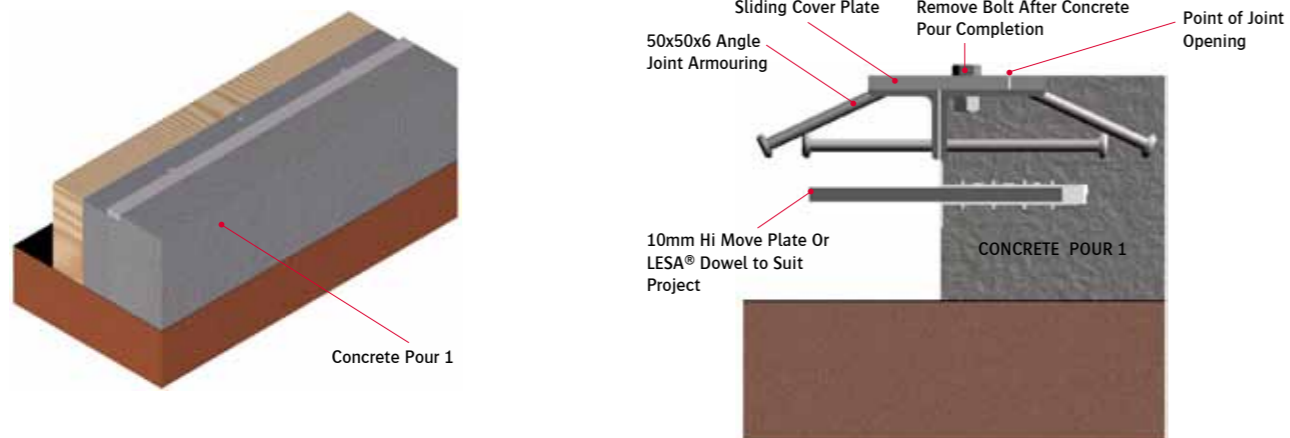

▶ 3

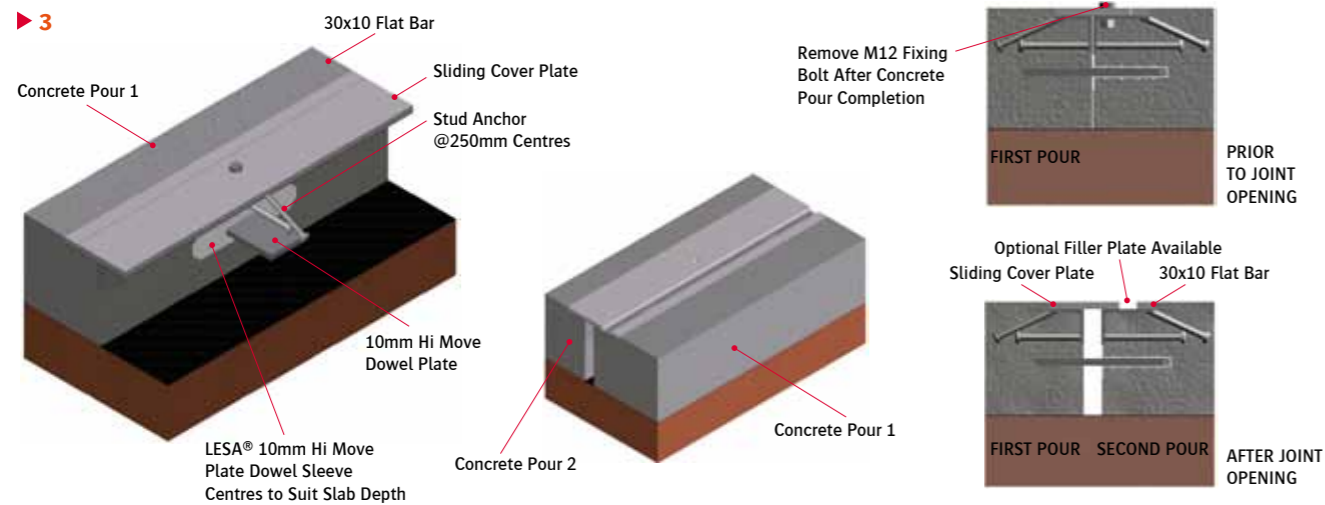

LESA® ARMOUR JOINT TYPE G-C™

▶ Lesa® Armour Joint Type G-C™ ©2009

Type G-C can be used where a new slab is poured against an existing slab, but a cover plate joint system is required. The first side is fabricated to enable it to be mounted into the edge of an existing slab.

▶ 1

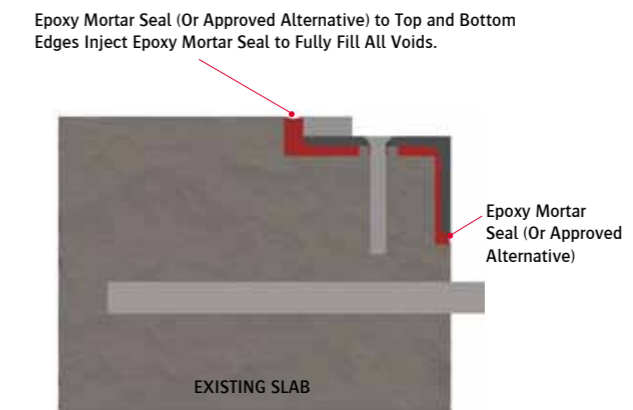

▶ 2

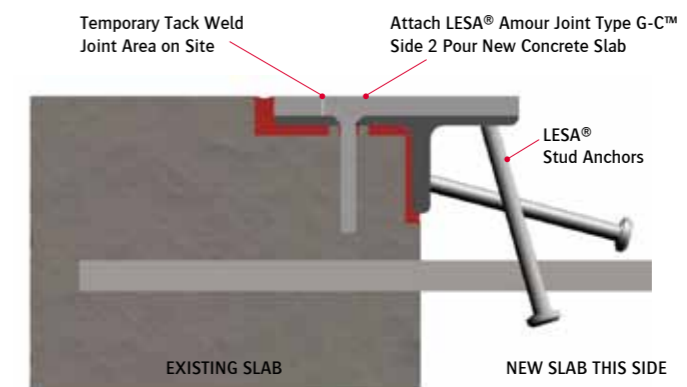

▶ 3

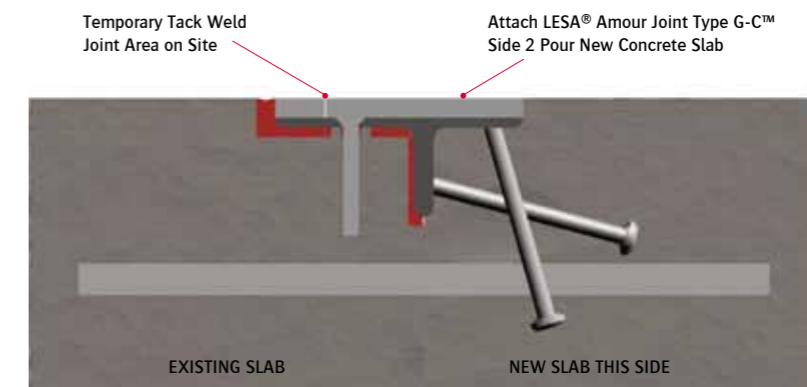

TYPE G
TYPE G-C

LESA® ARMOUR JOINT TYPE H™

LESA® ARMOUR JOINT TYPE K™

► Lesa® Armour Joint Type H™ ©2004

Type H is similar to the Type B version, providing flat bar steel edge protection, but for floors where wider joint openings are expected. It is a full, comprehensive, pre-assembled product but differs as it incorporates heavy duty Lesa® High-Move plate dowels for joint openings up to 35mm in most floors.

► 1

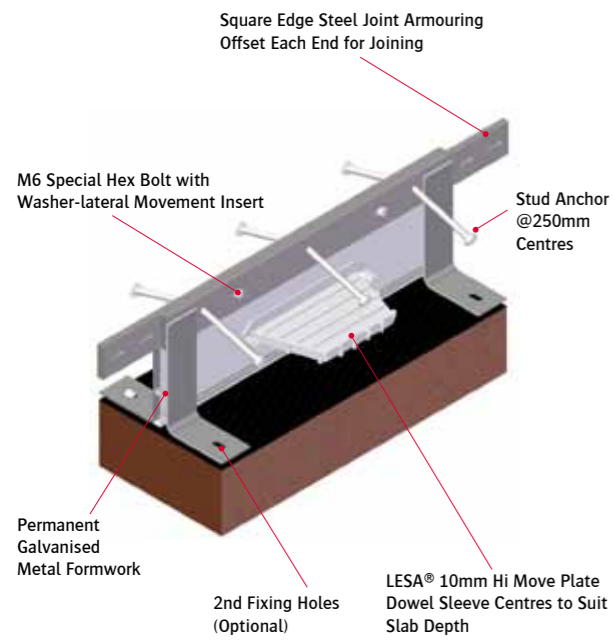

► 2

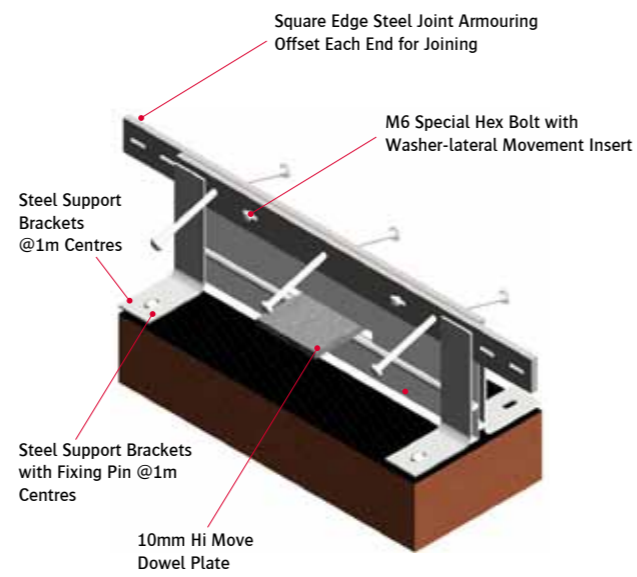

► 3

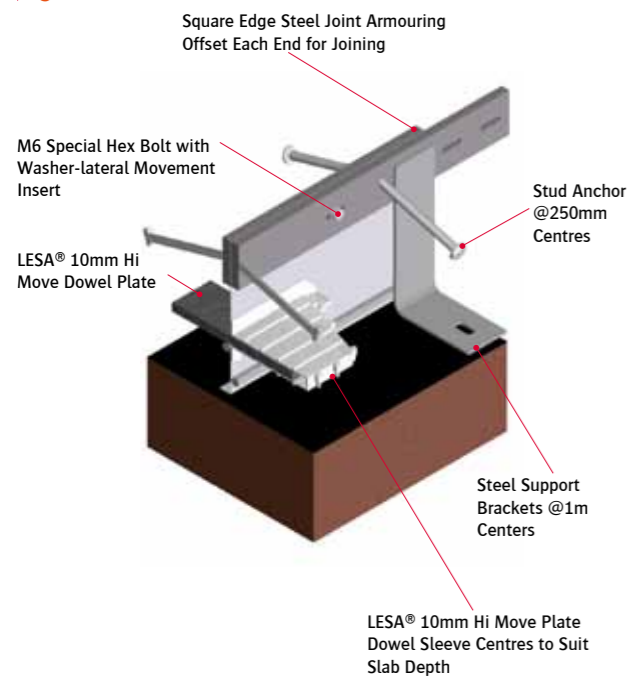

► **NOTE: OPTIONAL ADJUSTING BRACKETS ARE AVAILABLE FOR TYPE B & TYPE H FLAT BAR SYSTEMS. THIS MUST BE NOTED WHEN PLACING AN ORDER**

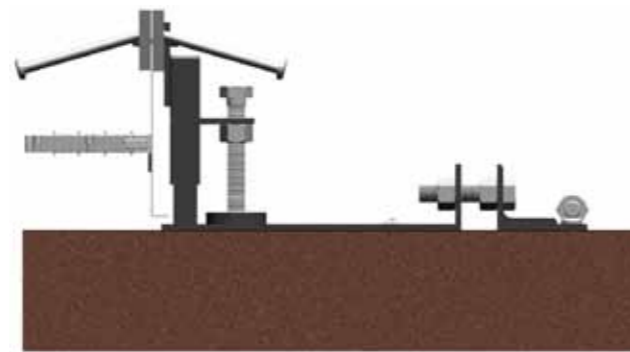

TYPE H
TYPE K

► Lesa® Armour Joint Type K™ ©2008

Type K is a budget version of Type B, and is available for slab thicknesses up to 200mm. It is fully pre-assembled, and its lighter construction is suitable for many circumstances and lighter floor loads with lower load transfer requirements.

► 1

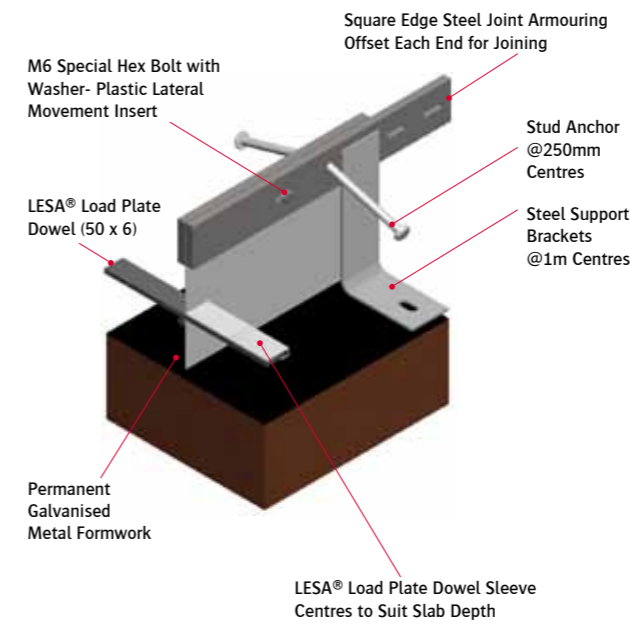

► 2

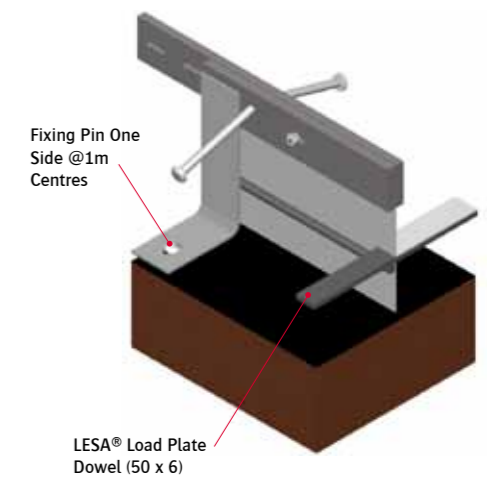

► 3

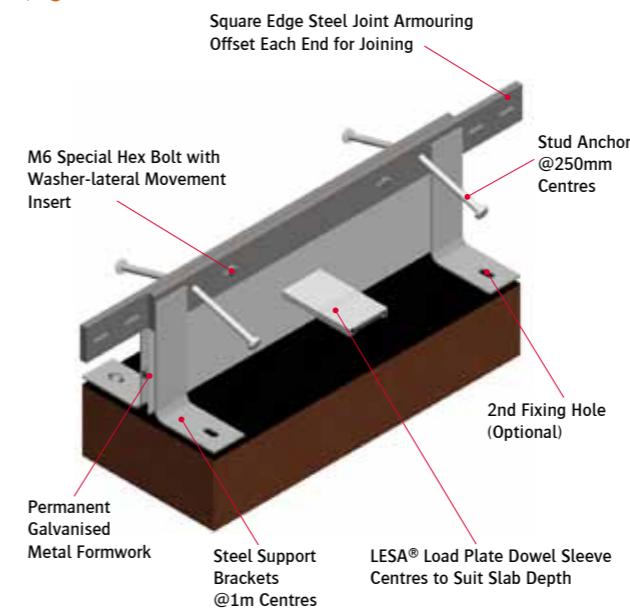

► 4



ARMOUR JOINT TYPE K - END VIEW

LESA® ARMOUR JOINT TYPE L™ - FOR JOINTS 45MM, 65MM & 85MM

LESA® ARMOUR JOINT TYPE M™

► Lesa® Armour Joint Type L™ ©2004

Type L is a full, comprehensive pre-assembled version of Armour Joint, with an upper, joint armoring section similar to Type L. This provides a cover plate over wider joints, and can be used where sealed joints are required. Up to 40mm joint movement is catered for with standard Type L, and special versions can cater for joint widths up to 85mm.

► 1

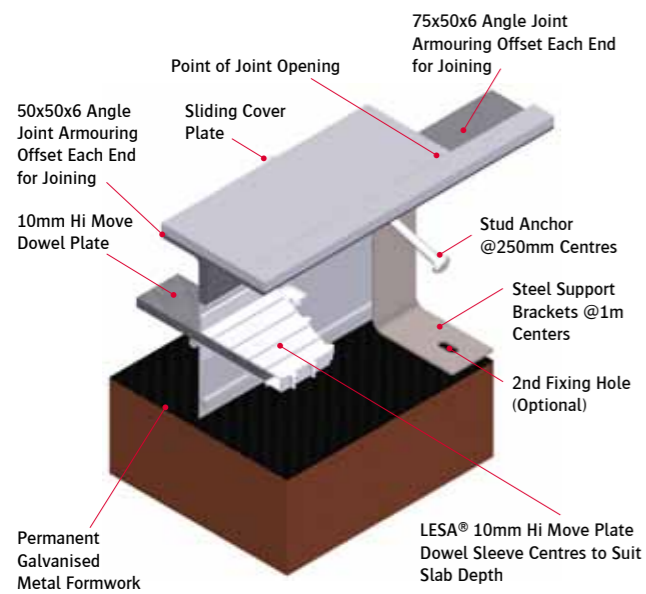

► 2

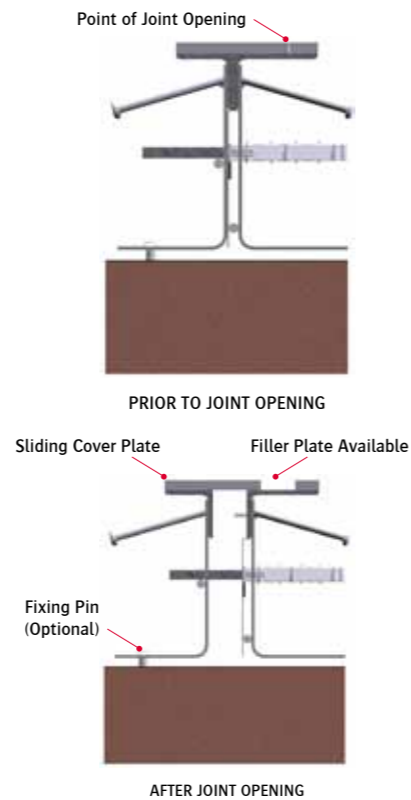

► 3

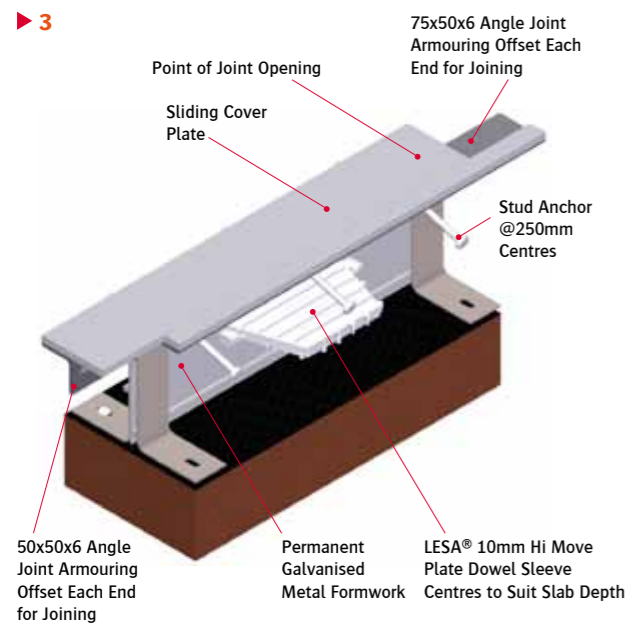

► **NOTE: OPTIONAL ADJUSTING BRACKETS ARE AVAILABLE FOR TYPE L FLAT BAR SYSTEMS. THIS MUST BE NOTED WHEN PLACING AN ORDER**

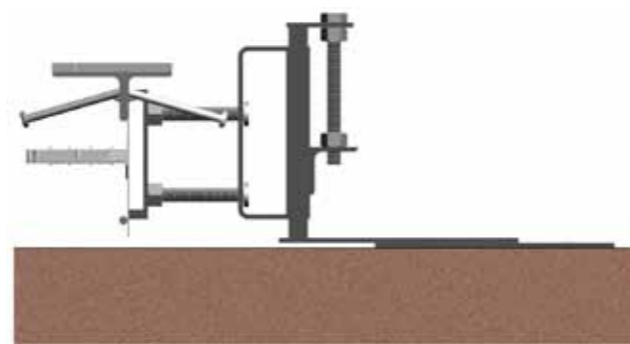

Note: Lesa® Armour Joint™ Type L incorporates Lesa® Hi-Move plate dowels or Lesa® Square Dowels, depending on the expected final joint width openings.

TYPE L

TYPE M

► Lesa® Armour Joint Type M™ ©2009

Type M is a budget version using steel angle edge protection, and is available for floor thicknesses up to 200mm. It is fully pre-assembled, incorporating dowels to suit lighter floor loads and load transfer requirement.

► 1

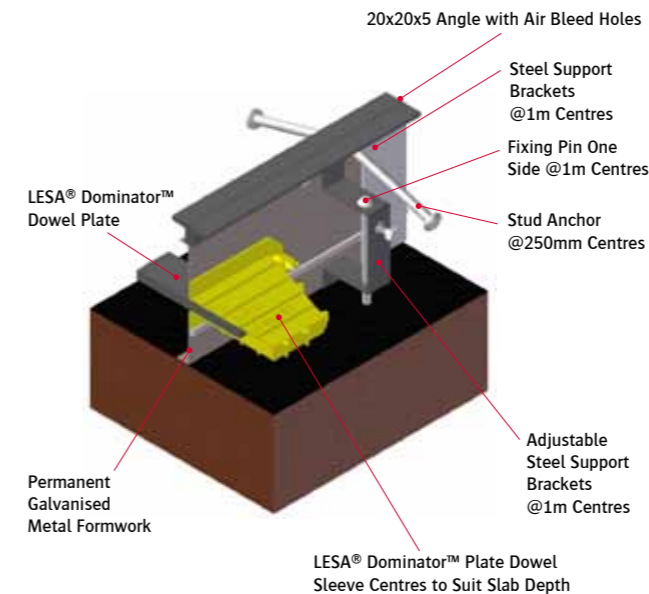

► 2

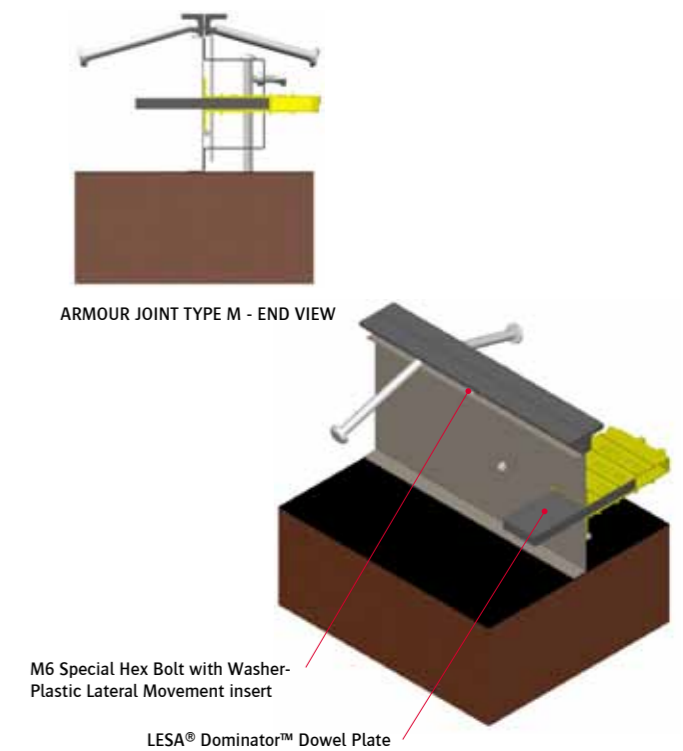

► 3

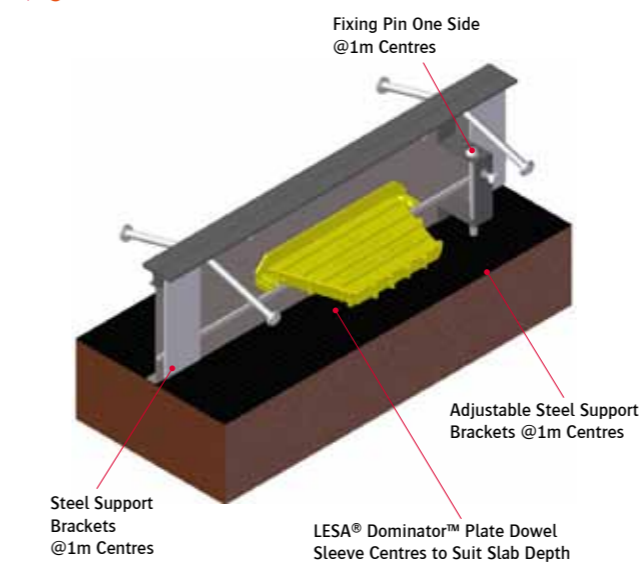

► 4

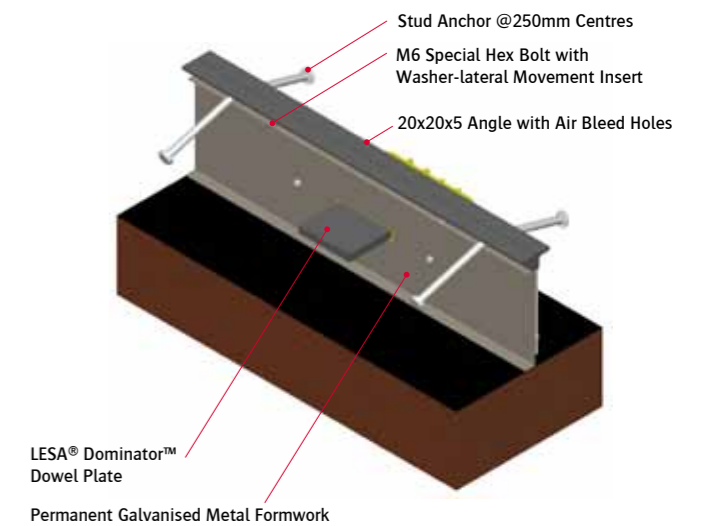



LESA® ARMOUR JOINT TYPE P™



LESA® T-FORM™ - SACRIFICIAL METAL FORMWORK SYSTEM

► Lesa® Armour Joint Type P™ ©2003

Type P is a fully assembled version using steel angles in place of flat bar for joint edge protection. This version is used where clients have a preference for steel angle joint edges, and is used installations such as supermarkets. Adjustable brackets are also available for Type P as a separate option. This must be noted when placing an order.

► 1

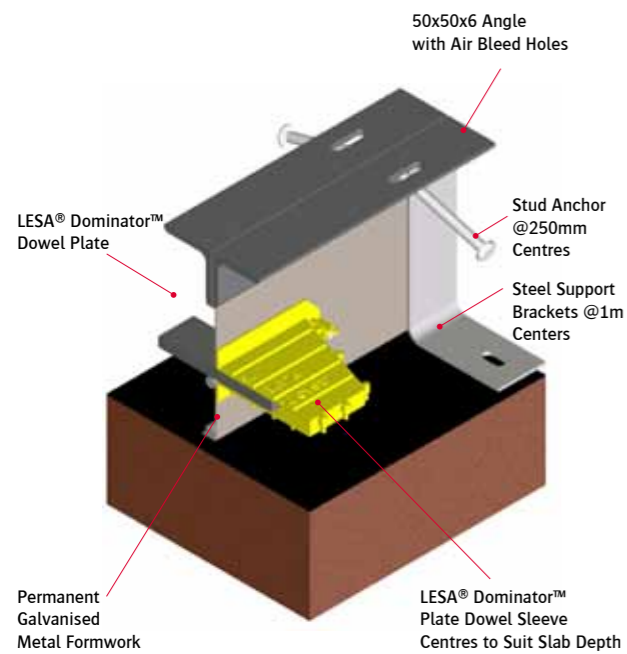

► 2

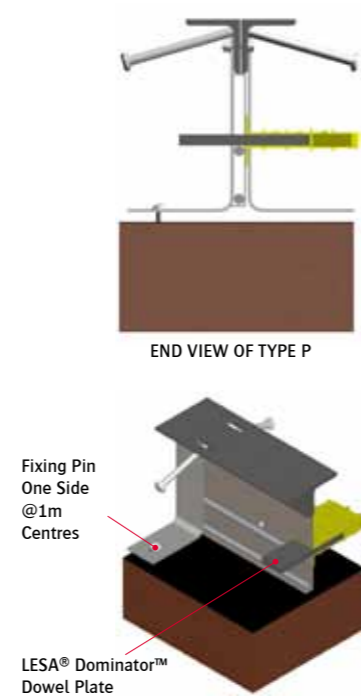

► 3

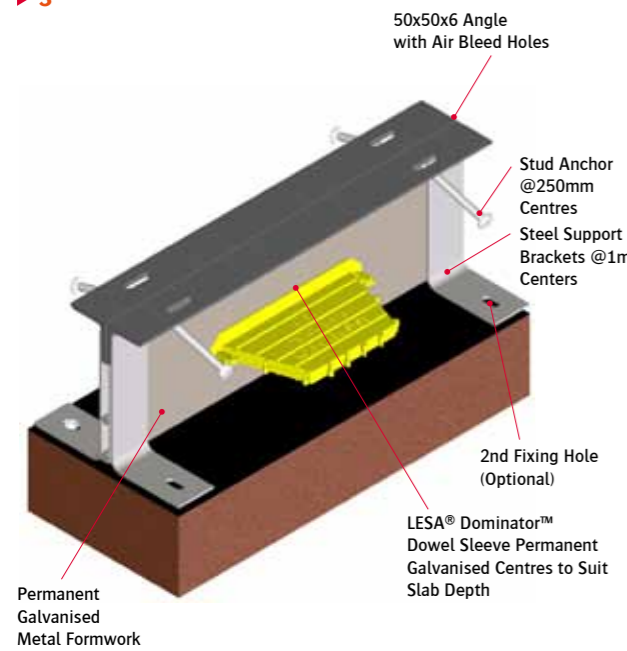

► 4

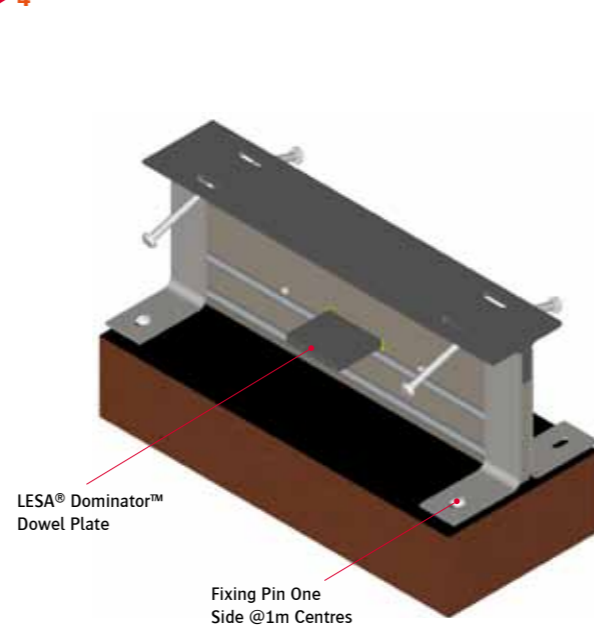

TYPE P
LESA® T-FORM

► Lesa® T-Form™ ©2004

Lesla® T-Form™ is a pre-assembled, self supporting permanent metal formwork system for creating doweled movement joints in slabs where armouring is not required. It can be used within a monolithic pour, or as an edge form. T-Form is supplied complete with any type of Lesla® Dowel & Sleeve (illustrated with Lesla® Dominator™ Plate Dowels) Fixing Pins & Joints.

► 1

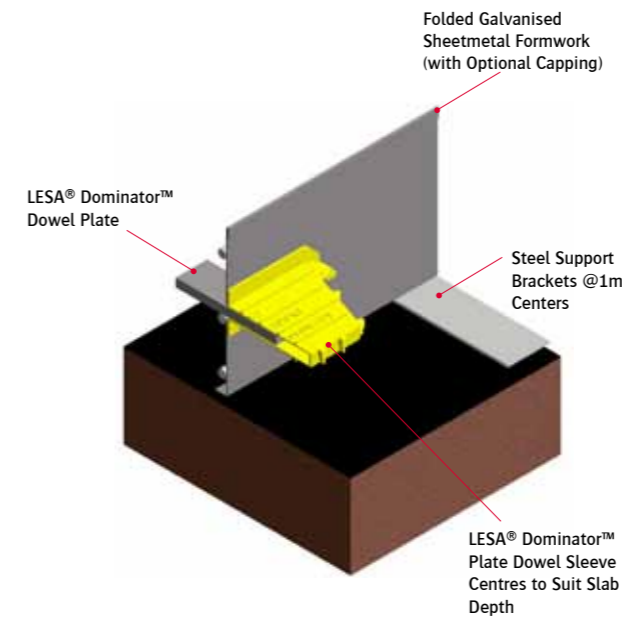

► 2

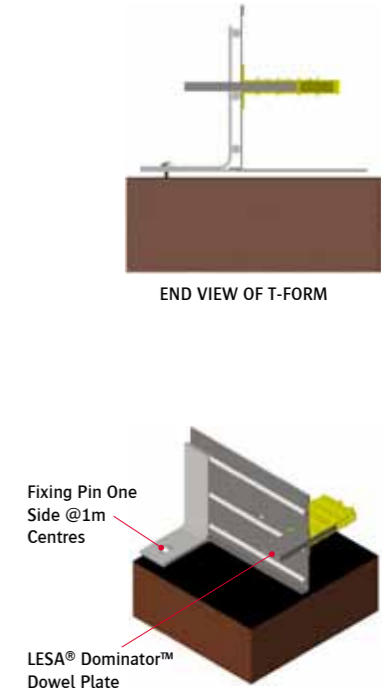

► 3

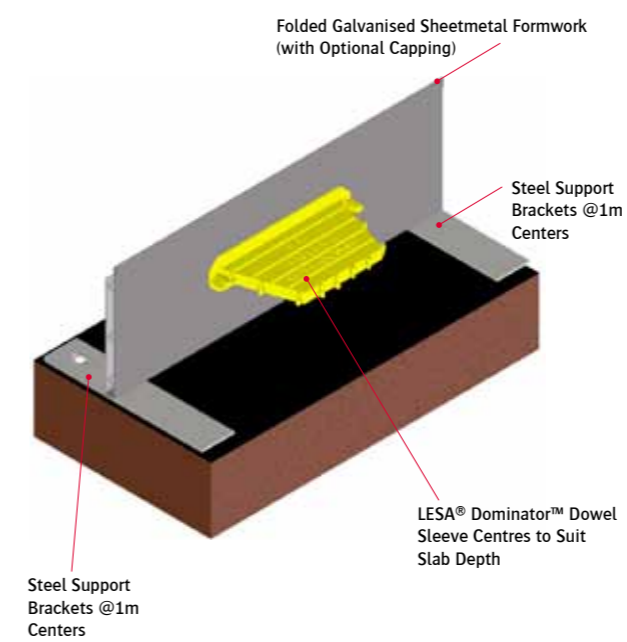

► **NOTE: A RANGE OF OPTIONAL PVC CAPPING IS ALSO AVAILABLE SUCH AS LESLA® REMOVABLE CAPPING TO FORM A REBATE FOR JOINT SEALANTS**

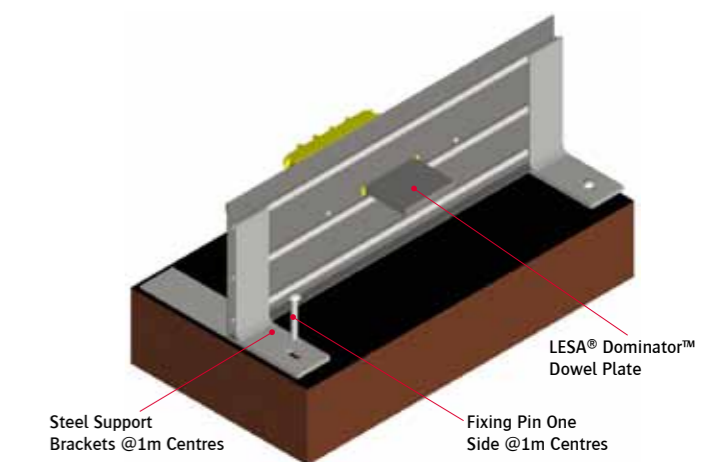



LESA® SPEED-FORM™ & LESA® SPEEDSCREED™

LESA® SYSTEMS - ENGINEERED CONCRETE FLOOR SYSTEMS

► **Lesas® Speed-Form™ ©2009**

Lesas® Speed-Form™ is a two piece permanent metal formwork system which provides a light steel protection to the edges of floor joints. It incorporates Lesas's "Ground Pin" fixing system for rapid, stable and easy installation to the correct height.

► 1

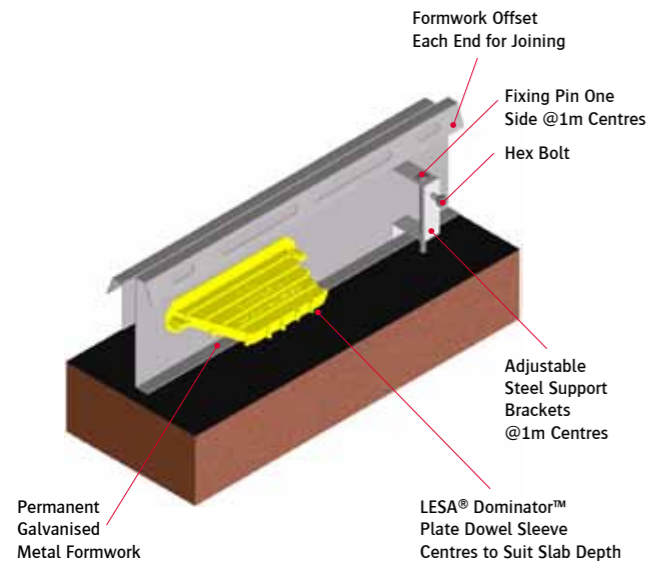

► 2

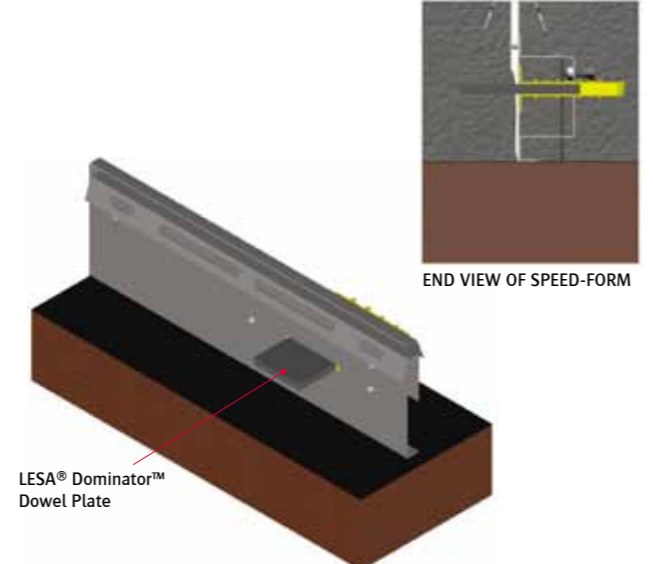

SPEED-FORM & SPEEDSCREED

► **Lesas® Speedscreed™ ©2002**

Lesas® Speedscreed™ is a pre-assembled, self supporting permanent formwork system designed to support truss screeds for super-flat floors. A square edged steel flat bar ensures accuracy and a permanent sheet metal form is pre-punched for continuity of the reinforcing through the joint.

► 1

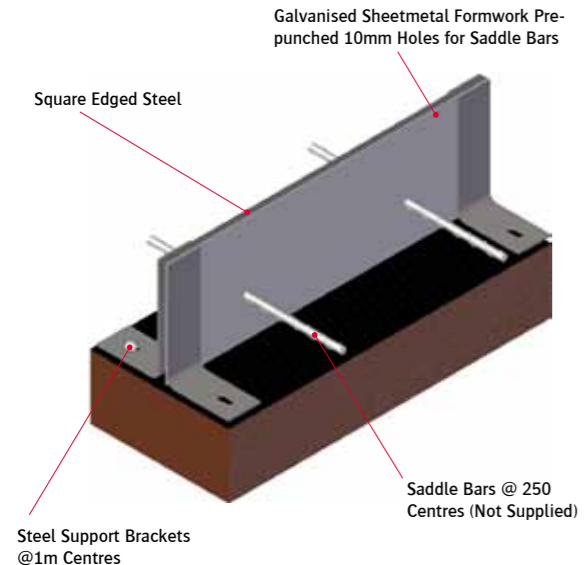

► 2

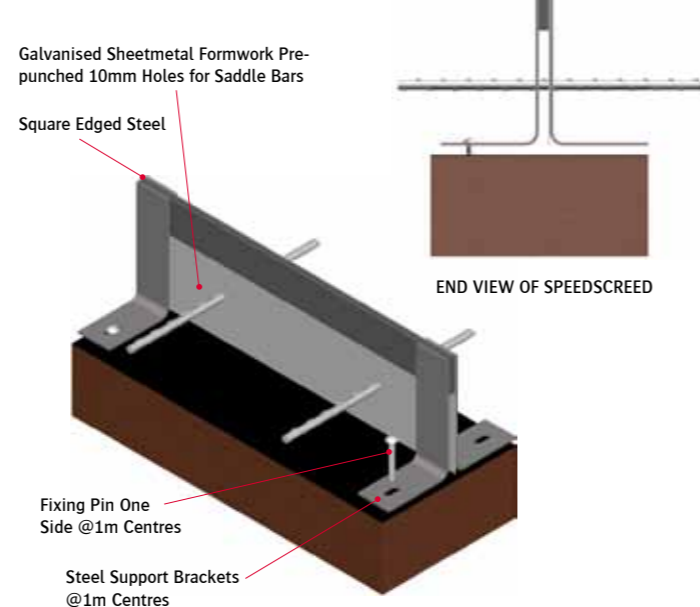

► **Joint Spacing, Layouts, and Details**

The correct layout of joints is essential in designing successful concrete slabs. A design service is available for this from Lesas® Systems.

Movement and other necessary joints must be correctly spaced in relation to the type of construction of the floor, and to any constraints to the movement of the concrete.

In addition, all intersections in movement joints and in Armour Joint products must be detailed to allow the movement joints to open freely. Lesas® Systems provides pre-manufactured junction sections for self supporting Armour Joint versions, and the use of these is essential to avoid incorrect site installation.

FREQUENTLY ASKED QUESTIONS

► **What Armouring Steel is Used?**

Lesas® Armour Joint™ uses high quality square edged mild steel. The square edges ensure a flush finish between steel and concrete floor surface. Lesas® avoids the use of bright steel sections since these have sharp edges which can damage the solid synthetic wheels on lift trucks. Radiused, or round topped steel is not used.

► **How is Lesas® Armour Joint™ Installed?**

A range of installation systems and procedures can be used, depending on the product and circumstances. Contact Lesas® Systems for the best installation system for your project, and for installation guidelines.

► **How do I Seal Lesas® Armour Joint™?**

The gap which develops in an armoured movement joint is dependant primarily on the spacing between the movement joints. In many installations, the gap which appears between the steel sections is left unsealed, since the armouring ensures that no damage will occur, and a sealed joint is not necessary.

Where a sealed joint is required, several different techniques can be used, depending on the product and the circumstances. For Lesas® Armour Joint™ Types A and B, Lesas® Armour Seal SR50 is the best sealant for use. For other circumstances, contact Lesas® Systems for specific advice

► **What Happens at Junctions in Lesas® Armour Joint™?**

When using Lesas® Armour Joint™, it is essential to use pre-formed junction sections. These ensure that the movement joints respond fully to concrete shrinkage movement, allowing joint gaps to form continuously, in both directions.

► **How Much Experience Does Lesas® Systems Have With Armour Joint?**

Lesas® Systems developed its first Armour Joint Types A and B in 1998, and has been manufacturing those and other versions of Armour Joint ever since. The Lesas® Armour Joint™ range has been tried and proven in thousands of installations.

Note: The information contained in this brochure is correct at the time of print however, changes and improvements can occur. It is recommended that all current details be obtained prior to purchase.



AUSTRALIA

EMAIL:
admin@lesasystems.com.au

PHONE:
1300 04 LESA

WEB:
www.lesasystems.com.au

FAX:
07 3207 3722

AUCKLAND

EMAIL:
sales@lesasystems.co.nz

PHONE:
0800 74 LESA

WEB:
www.lesasystems.co.nz

FAX:
09 5252 139

CHRISTCHURCH

EMAIL:
sales@lesasystems.co.nz

PHONE:
0800 74 LESA

WEB:
www.lesasystems.co.nz

FAX:
03 385 6398

